

---

**ALPHA WIRE COMPANY  
CUSTOMER SPECIFICATION**

---

Part Number: FITSLV 22-26  
Page 1 of 3 Pages

Issue: 1  
Issue Date: 10/27/2008  
Effective Date: 11/27/2008

---

-NOTE: ALL DIMENSIONS ARE IN INCHES UNLESS OTHERWISE SPECIFIED-

**A. Construction**

- |                         |   |
|-------------------------|---|
| 1) Product              | Soldering Sleeves   |
| 2) Insulation Sleeve    | Radiation Crosslinked, Modified Polyvinylidene Flouride         |
| 3) Meltable Sealin Ring | Thermally Stablized Thermoplastic Alloy – Sn63 Eutectic @ 183°C |
| 4) Solder Preform       | Flux – Ro11 Type RMA Flux for tin or silver applications.       |

**B.) Industry Approvals**

- |                         |                |
|-------------------------|----------------|
| 1) Other                |                |
| a) FitSleeve            | NAS1745        |
| b) Solder Preform Alloy | ANSI-J-STD-006 |
| c) Solder Preform Flux  | ANSI-J-STD-004 |

**B. Physical Properties**

- |                          |                  |
|--------------------------|------------------|
| 1) Operating Temperature | -55°C to +150°C  |
| 2) Immersion resistant   | Water            |
| 3) Color                 |                  |
| a) Insulation Sleeve     | Transparent blue |
| b) Meltable Seal Ring    | 2 clear          |

**C. Finished Product Requirements**

- |                              |                                     |
|------------------------------|-------------------------------------|
| 1) Dimensions                | See Table 1, Figure 1               |
| 2) Shelf Life                | 25 years                            |
| 3) RoHS Directive 2002/95/EC | This material is NOT RoHS compliant |

**D. Cable Perparation Measurements**

See Table 2, Figure 2

**E. Other**

- |              |                           |
|--------------|---------------------------|
| 1) Packaging | 25 pc., 100 pc., Packages |
|--------------|---------------------------|

This technical specification outlines the requirements for the products described herein. Deviations from this specification are **not permitted** without the written authorization of the Alpha Wire Engineering Department. All finished products will be inspected to this specification and noncompliance or unauthorized deviations will be cause for rejection and return of product.

All information contained herein is confidential. It's use is restricted to authorized Alpha Wire Company personnel or authorized vendors of the Alpha Wire Company. Under no circumstances shall this document be duplicated in any form or shown to/discussed with unauthorized personnel without the expressed written consent of the Alpha Wire Engineering Department.

**ALPHA WIRE COMPANY  
CUSTOMER SPECIFICATION**

Part Number: FITSLV 22-26  
Page 2 of 3 Pages

Issue: 1  
Issue Date: 10/27/2008  
Effective Date: 11/27/2008

Table 1

Alpha P/N	L +/- 0.062	øD Minimum	øD1 Minimum
FSLV12	0.625	0.110	0.125
FSLV14	0.625	0.180	0.200
FSLV16	0.750	0.280	0.300

Figure 1

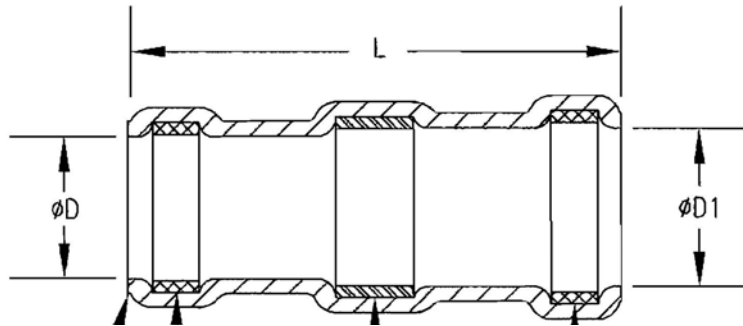

Table 2

Alpha P/N	øD2 Maximum	øD3 Minimum	øD4 Maximum	øD4 Minimum	L2 Range
FSLV12	0.125	0.055	0.110	0.030	0.250 – 0.325
FSLV14	0.200	0.085	0.175	0.050	0.250 – 0.325
FSLV16	0.300	0.170	0.280	0.100	0.250 – 0.325

Figure 2

RECOMMENDED CABLE PREPARATIONS:



This technical specification outlines the requirements for the products described herein. Deviations from this specification are **not permitted** without the written authorization of the Alpha Wire Engineering Department. All finished products will be inspected to this specification and noncompliance or unauthorized deviations will be cause for rejection and return of product.

All information contained herein is confidential. Its use is restricted to authorized Alpha Wire Company personnel or authorized vendors of the Alpha Wire Company. Under no circumstances shall this document be duplicated in any form or shown to/discussed with unauthorized personnel without the expressed written consent of the Alpha Wire Engineering Department.

---

**ALPHA WIRE COMPANY  
CUSTOMER SPECIFICATION**

---

Part Number: FITSLV 22-26  
Page 3 of 3 Pages

Issue: 1  
Issue Date: 10/27/2008  
Effective Date: 11/27/2008

---

This technical specification outlines the requirements for the products described herein. Deviations from this specification are **not permitted** without the written authorization of the Alpha Wire Engineering Department. All finished products will be inspected to this specification and noncompliance or unauthorized deviations will be cause for rejection and return of product.

All information contained herein is confidential. It's use is restricted to authorized Alpha Wire Company personnel or authorized vendors of the Alpha Wire Company. Under no circumstances shall this document be duplicated in any form or shown to/discussed with unauthorized personnel without the expressed written consent of the Alpha Wire Engineering Department.